



EX NAVODAYAN FOUNDATION

(Registered Under Indian Trust Act 1882)

Reg. No. : 2016, 43

B/36/43 46M Brahmanand Colony, Durgakund, Varanasi (UP) 221005

Mob.: 8958143003

Email Id : exnavodayanfoundation@gmail.com

29/01/2023

Morning

Answers & Solutions

Time : 3 hrs.

for

M.M. : 300

JEE (Main)-2023 (Online) Phase-1

(Physics, Chemistry and Mathematics)

IMPORTANT INSTRUCTIONS:

- (1) The test is of **3 hours** duration.
- (2) The Test Booklet consists of 90 questions. The maximum marks are 300.
- (3) There are **three** parts in the question paper consisting of **Physics, Chemistry** and **Mathematics** having 30 questions in each part of equal weightage. Each part (subject) has two sections.
 - (i) **Section-A:** This section contains 20 multiple choice questions which have only one correct answer. Each question carries **4 marks** for correct answer and **-1 mark** for wrong answer.
 - (ii) **Section-B:** This section contains 10 questions. In Section-B, attempt any **five questions out of 10**. The answer to each of the questions is a numerical value. Each question carries **4 marks** for correct answer and **-1 mark** for wrong answer. For Section-B, the answer should be rounded off to the nearest integer.

Sol.

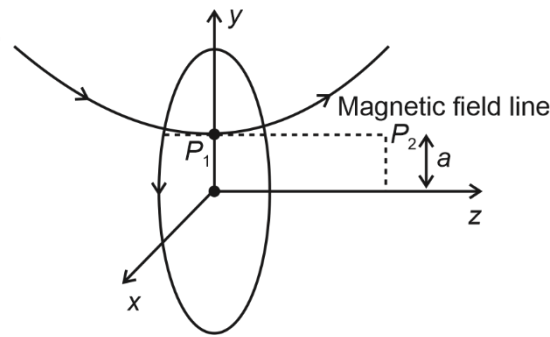

$\therefore B_y$ at $P_1 = 0$ [option 2 and 4 are incorrect]

B_y has the opposite direction for the +ve and -ve z axis

5. A car is moving on a horizontal curved road with radius 50 m. The approximate maximum speed of car will be, if friction between tyres and road is 0.34. [take $g = 10 \text{ ms}^{-2}$]

- (1) 22.4 ms^{-1}
- (2) 13 ms^{-1}
- (3) 17 ms^{-1}
- (4) 3.4 ms^{-1}

Answer (2)

Sol. $v_{\text{max}} = \sqrt{\mu g R}$
 $= \sqrt{0.34 \times 10 \times 50}$
 $\approx 13 \text{ m/s}$

6. The magnitude of magnetic induction at mid point O due to current arrangement as shown in Fig. will be

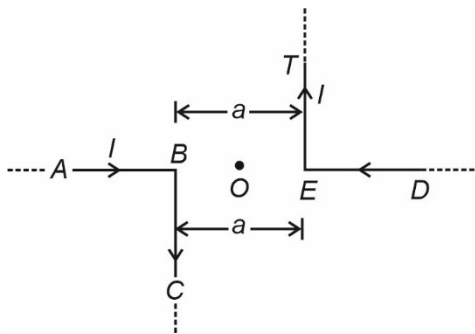

- (1) 0
- (2) $\frac{\mu_0 I}{4\pi a}$
- (3) $\frac{\mu_0 I}{\pi a}$
- (4) $\frac{\mu_0 I}{2\pi a}$

Answer (3)

Sol. $B_0 = 2 \left[\frac{\mu_0 I}{4\pi \left(\frac{a}{2}\right)} [\sin 0^\circ + \sin 90^\circ] \right]$
 $= \frac{\mu_0 I}{\pi a}$

7. A stone is projected at angle 30° to the horizontal. The ratio of kinetic energy of the stone at point of projection to its kinetic energy at the highest point of flight will be -

- (1) 4 : 3
- (2) 4 : 1
- (3) 1 : 2
- (4) 1 : 4

Answer (1)

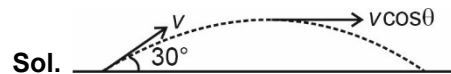

Sol.

$$KE_{\text{in}} = \frac{1}{2} m v^2$$

$$KE_{\text{final}} = \frac{1}{2} m v^2 \cos^2 30^\circ = \frac{1}{2} m v^2 \left(\frac{\sqrt{3}}{2}\right)^2$$

$$\frac{KE_{\text{in}}}{KE_{\text{f}}} = \frac{\frac{1}{2} m v^2}{\frac{1}{2} m v^2 \left(\frac{3}{4}\right)} = \frac{4}{3}$$

8. Two particles of equal mass 'm' move in a circle of radius 'r' under the action of their mutual gravitational attraction. The speed of each particle will be :

- (1) $\sqrt{\frac{Gm}{2r}}$
- (2) $\sqrt{\frac{Gm}{4r}}$
- (3) $\sqrt{\frac{4Gm}{r}}$
- (4) $\sqrt{\frac{Gm}{r}}$

Answer (2)

Sol.

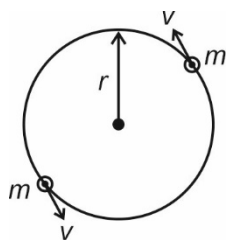

From one of the masses FBD

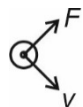

$$\frac{Gm^2}{(2r)^2} = \frac{mv^2}{r}$$

$$v = \sqrt{\frac{Gm}{4r}}$$

9. A bicycle tyre is filled with air having pressure of 270 kPa at 27°C. The approximate pressure of the air in the tyre when the temperature increases to 36°C is

- (1) 270 kPa
- (2) 278 kPa
- (3) 360 kPa
- (4) 262 kPa

Answer (2)

Sol. $P_{in} = 270 \text{ kPa}$, $T_{in} = 27^\circ\text{C}$
 $= 300 \text{ K}$

$$T_{final} = 36^\circ\text{C} = 309 \text{ K}$$

Hence we can consider process to be isochoric
 volume constant

$$\therefore P \propto T$$

$$\frac{P_{in}}{P_f} = \frac{T_{in}}{T_f} \Rightarrow P_f = 278 \text{ kPa}$$

10. Given below are two statements: One is labelled as **Assertion A** and the other is labelled as **Reason R**.

Assertion A : If dQ and dW represent the heat supplied to the system and the work done on the system respectively. Then according to the first law of thermodynamics $dQ = dU - dW$.

Reason R : First law of thermodynamics is based on law of conservation of energy.

In the light of the above statements, choose the correct answer from the options given below :

- (1) Both A and R are correct and R is the correct explanation of A
- (2) A is correct but R is not correct

- (3) A is not correct but R is correct
- (4) Both A and R are correct but R is not the correct explanation of A

Answer (1)

Sol. $\Delta Q =$ heat supplied to system

$\Delta W =$ work done on the system

$$\therefore \Delta U = \Delta Q - \Delta W$$

This comes from conservation of energy.

11. In a cuboid of dimension $2L \times 2L \times L$, a charge q is placed at the center of the surface 'S' having area of $4L^2$. The flux through the opposite surface to 'S' is given by

$$(1) \frac{q}{2\epsilon_0}$$

$$(2) \frac{q}{6\epsilon_0}$$

$$(3) \frac{q}{12\epsilon_0}$$

$$(4) \frac{q}{3\epsilon_0}$$

Answer (2)

Sol.

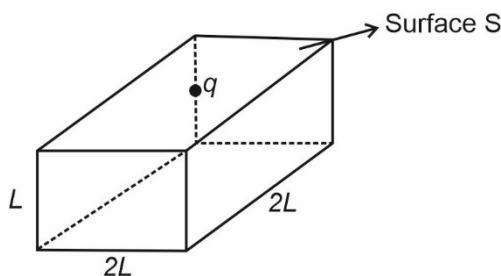

If we consider a similar box above this box then it becomes cube of side length $2L$

$$\phi \text{ through a surface} = \frac{q}{6\epsilon_0}$$

12. Which one of the following statement is not correct in the case of light emitting diodes?
- A. It is a heavily doped p-n junction.
 - B. It emits light only when it is forward biased.
 - C. It emits light only when it is reverse biased.
 - D. The energy of the light emitted is equal to or slightly less than the energy gap of the semiconductor used.

Choose the correct answer from the options given below:

- (1) C and D (2) C
 (3) B (4) A

Answer (2)

Sol. ⇒ LED is a heavily doped, forward biased $p-n$ -junction diode

- ⇒ It will not emit light in reverse bias
 ⇒ Energy of emitted photon is equal to or slightly less the band gap energy of forbidden band.

13. Match List I with List II:

	List I (Physical Quantity)		List II (Dimensional Formula)
A.	Pressure gradient	I.	$[M^0L^2T^{-2}]$
B.	Energy density	II.	$[M^1L^{-1}T^{-2}]$
C.	Electric field	III.	$[M^1L^{-2}T^{-2}]$
D.	Latent heat	IV.	$[M^1L^1T^{-3}A^{-1}]$

Choose the **correct** answer from the options given below:

- (1) A-III, B-II, C-IV, D-I (2) A-II, B-III, C-I, D-IV
 (3) A-III, B-II, C-I, D-IV (4) A-II, B-III, C-IV, D-I

Answer (1)

Sol. A. $\frac{\Delta P}{\Delta x} = \left[\frac{MLT^{-2}}{L^3} \right] = [ML^{-2}T^{-2}] \dots (III)$

B. $\frac{E}{v} = \left[\frac{ML^2T^{-2}}{L^3} \right] = [ML^{-1}T^{-2}] \dots (II)$

C. $\frac{F}{Q} = \left[\frac{MLT^{-2}}{AT} \right] = [MLT^{-3}A^{-1}] \dots (IV)$

D. Latent heat = $\left[\frac{ML^2T^{-2}}{M} \right] = [M^0L^2T^{-2}] \dots (I)$

14. Which of the following are true?

- A. Speed of light in vacuum is dependent on the direction of propagation.
 B. Speed of light in a medium is independent of the wavelength of light.
 C. The speed of light is independent of the motion of the source.
 D. The speed of light in a medium is independent of intensity.

Choose the correct answer from the options given below:

- (1) C and D only (2) B and D only
 (3) B and C only (4) A and C only

Answer (1)

Sol. Speed of light is independent of motion of source and Intensity.

15. In a Young's double slit experiment, two slits are illuminated with a light of wavelength 800 nm. The line joining A_1P is perpendicular to A_1A_2 as shown in the figure. If the first minimum is detected at P , the value of slits separation 'a' will be:

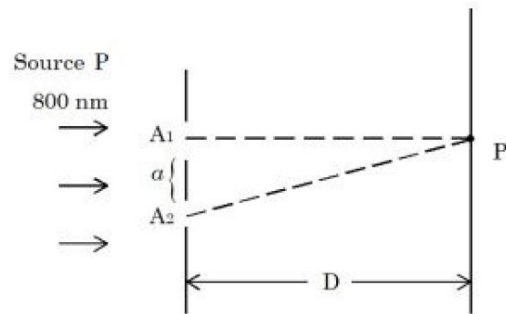

The distance of screen from slits $D = 5 \text{ cm}$

- (1) 0.4 mm
 (2) 0.1 mm
 (3) 0.2 mm
 (4) 0.5 mm

Answer (3)

Sol. $y = \frac{(2n-1)\lambda D}{2a} = \frac{a}{2}$ for $n = 1$

⇒ $\frac{\lambda D}{2a} = \left(\frac{a}{2} \right)$

⇒ $\frac{800 \times 10^{-9} \times 5 \times 10^{-2}}{2} = \frac{a^2}{2}$

⇒ $a^2 = 4000 \times 10^{-11}$

$a = \sqrt{4 \times 10^{-8}} = 2 \times 10^{-4} = 0.2 \text{ mm}$

16. If the height of transmitting and receiving antennas are 80 m each, the maximum line of sight distance will be:

Given: Earth's radius = $6.4 \times 10^6 \text{ m}$

- (1) 64 km (2) 36 km
 (3) 28 km (4) 32 km

Answer (1)



Maximum line of sight = $2\sqrt{2Rh}$

$$= 2\sqrt{2 \times 6.4 \times 10^6 \times 80}$$

$$= 2 \times 4 \times 8 \times 10^3$$

$$= 64 \times 10^3$$

$$= 64 \text{ km}$$

17. Find the mutual inductance in the arrangement, when a small circular loop of wire of radius 'R' is placed inside a large square loop of wire of side L ($L \gg R$). The loops are coplanar and their centres coincide:

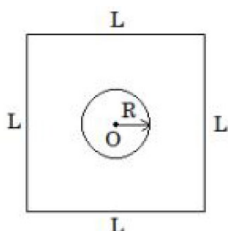

- (1) $M = \frac{2\sqrt{2}\mu_0 R}{L^2}$ (2) $M = \frac{\sqrt{2}\mu_0 R}{L^2}$
- (3) $M = \frac{2\sqrt{2}\mu_0 R^2}{L}$ (4) $M = \frac{\sqrt{2}\mu_0 R^2}{L}$

Answer (3)

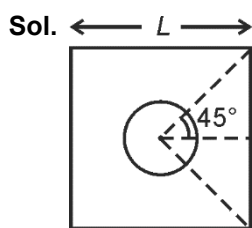

$$B \text{ at centre} = \frac{\mu_0 i}{4\pi \left(\frac{L}{2}\right)} \left(\frac{2}{\sqrt{2}}\right) \times 4$$

$$= \frac{\sqrt{2}\mu_0 i}{2\pi L} \times 4$$

$$= \left(\frac{2\sqrt{2}\mu_0 i}{\pi L}\right)$$

$$\text{Mutual inductance} = \frac{B \cdot A}{i}$$

$$= \frac{2\sqrt{2}\mu_0 i}{\pi L} \times \frac{\pi R^2}{i}$$

$$= \left(\frac{2\sqrt{2}\mu_0 R^2}{L}\right)$$

18. Ratio of thermal energy released in two resistors R and 3R connected in parallel in an electric circuit is:
- (1) 1 : 1 (2) 1 : 3
- (3) 1 : 27 (4) 3 : 1

Answer (4)

Sol. For parallel connection, potential difference is same (v)

$$P_1 = \left(\frac{v^2}{R_1}\right)$$

$$P_2 = \left(\frac{v^2}{R_2}\right)$$

$$\frac{P_1}{P_2} = \frac{H_1}{H_2} = \left(\frac{R_2}{R_1}\right) = \frac{3R}{R} = (3 : 1)$$

19. The threshold wavelength for photoelectric emission from a material is 5500 Å. Photoelectrons will be emitted, when this material is illuminated with monochromatic radiation from a
- A. 75 W infra-red lamp
- B. 10 W infra-red lamp
- C. 75 W ultra-violet lamp
- D. 10 W ultra-violet lamp

Choose the correct answer from the options given below:

- (1) A and D only (2) C only
- (3) C and D only (4) B and C only

Answer (3)

Sol. Wavelength of infra-red = 700 nm (minimum)

Wavelength of UV = 100 – 400 nm

Since we need $\lambda < 5000 \text{ \AA}$

⇒ Only UV would be able to emit photoelectrons.

20. A person observes two moving trains, 'A' reaching the station and 'B' leaving the station, with equal speed of 30 m/s. If both trains emit sounds with frequency 300 Hz, (Speed of sound: 330 m/s) approximate difference of frequencies heard by the person will be:

- (1) 33 Hz (2) 10 Hz
- (3) 55 Hz (4) 80 Hz

Answer (3)

Sol. By doppler effect : $f' = f_0 \left[\frac{v - v_0}{v - v_s} \right]$

$$\Rightarrow f'_A = 300 \left[\frac{330}{330 - 30} \right] \text{ Hz}$$

$$= 330 \text{ Hz}$$

And $f'_B = 300 \left[\frac{330}{330 + 30} \right] \text{ Hz}$

$$= \frac{5}{6} \times 330 \text{ Hz} = 275 \text{ Hz}$$

SECTION - B

Numerical Value Type Questions: This section contains 10 questions. In Section B, attempt any five questions out of 10. The answer to each question is a **NUMERICAL VALUE**. For each question, enter the correct numerical value (in decimal notation, truncated/rounded-off to the second decimal place; e.g. 06.25, 07.00, -00.33, -00.30, 30.27, -27.30) using the mouse and the on-screen virtual numeric keypad in the place designated to enter the answer.

21. A certain elastic conducting material is stretched into a circular loop. It is placed with its plane perpendicular to a uniform magnetic field $B = 0.8 \text{ T}$. When released the radius of the loop starts shrinking at a constant rate of 2 cms^{-1} . The induced emf in the loop at an instant when the radius of the loop is 10 cm will be _____ mV.

Answer (10)

Sol. $\varepsilon = \frac{-d\phi}{dt}$

$$= -\frac{d}{dt} [B \cdot \pi r^2]$$

$$= -\pi B \left[2r \frac{dr}{dt} \right]$$

$$= 2 \times \pi \times 0.8 \times \frac{10}{100} \times \left(\frac{-2}{100} \right) \text{ Volts}$$

$$\Rightarrow \varepsilon \approx -10.048 \text{ mV}$$

22. A 0.4 kg mass takes 8 s to reach ground when dropped from a certain height 'P' above surface of earth. The loss of potential energy in the last second of fall is _____ J.

(Take $g = 10 \text{ m/s}^2$)

Answer (300)

Sol. $8 = \sqrt{\frac{2h}{g}}$

$$\Rightarrow h = 320 \text{ m}$$

Distance covered in last second

$$= \frac{1}{2} g \times 8^2 - \frac{1}{2} g \times 7^2$$

$$h' = 75 \text{ m}$$

$$\Rightarrow \text{Loss of potential energy} = mgh'$$

$$= 0.4 \times 10 \times 75 \text{ J}$$

$$= 300 \text{ J}$$

23. As shown in the figure, three identical polaroids P_1 , P_2 and P_3 are placed one after another. The pass axis of P_2 and P_3 are inclined at angle of 60° and 90° with respect to axis of P_1 . The source S has an intensity of $256 \frac{\text{W}}{\text{m}^2}$.

The intensity of light at point O is _____ $\frac{\text{W}}{\text{m}^2}$.

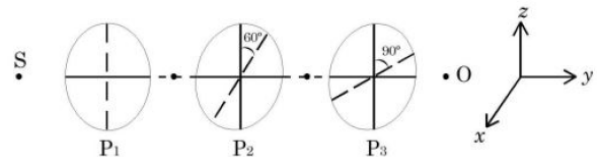

Answer (24)

Sol. Using Malus' law, intensity would be

$$I = I_0 \times \frac{1}{2} \times \cos^2 60^\circ \times \cos^2 (90^\circ - 60^\circ)$$

$$= 256 \times \frac{1}{2} \times \frac{1}{4} \times \frac{3}{4} \text{ W/m}^2$$

$$\Rightarrow I = 24 \text{ W/m}^2$$

24. A point charge $q_1 = 4q_0$ is placed at origin. Another point charge $q_2 = -q_0$ is placed at $x = 12 \text{ cm}$. Charge of proton is q_0 . The proton is placed on x axis so that the electrostatic force on the proton is zero. In this situation, the position of the proton from the origin is _____ cm.

Answer (24)

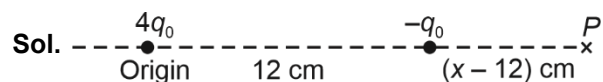

Field at point $P = 0$

$$\Rightarrow \frac{1}{4\pi\epsilon_0} \frac{4q_0}{x^2} = \frac{1}{4\pi\epsilon_0} \frac{q_0}{(x-12)^2}$$

$$\Rightarrow x = 2(x-12) \Rightarrow x = 24 \text{ cm}$$

25. A solid sphere of mass 2 kg is making pure rolling on a horizontal surface with kinetic energy 2240 J. The velocity of centre of mass of the sphere will be _____ ms^{-1} .

Answer (40)

Sol. $\frac{1}{2}mv_{\text{cm}}^2 + \frac{1}{2} \times \frac{2}{5}mR^2 \times \frac{v_{\text{cm}}^2}{R^2} = 2240 \text{ J}$

$$\frac{7}{10}mv_{\text{cm}}^2 = 2240$$

$$v_{\text{cm}} = \sqrt{\frac{2240 \times 10}{7 \times 2}} = 40 \text{ m/sec}$$

26. Two simple harmonic waves having equal amplitudes of 8 cm and equal frequency of 10 Hz are moving along the same direction. The resultant amplitude is also 8 cm. The phase difference between the individual waves is _____ degree.

Answer (120)

Sol. $A_R = \sqrt{A_1^2 + A_2^2 + 2A_1A_2 \cos \phi}$

$$8 = \sqrt{8^2 + 8^2 + 2 \times 8 \times 8 \cos \phi}$$

$$\Rightarrow \cos \phi = -\frac{1}{2}$$

$$\Rightarrow \phi = 120^\circ$$

27. In a metre bridge experiment the balance point is obtained if the gaps are closed by 2Ω and 3Ω . A shunt of $X \Omega$ is added to 3Ω resistor to shift the balancing point by 22.5 cm. The value of X is _____.

Answer (2)

Sol. Case 1:

$$\frac{l}{100-l} = \frac{2}{3}$$

$$\Rightarrow l = 40 \text{ cm}$$

as 3Ω is shunted the balance point will shift towards 3Ω . So, new length $l' = 22.5 + l = 62.5$

$$\text{So, } \frac{62.5}{37.5} = \frac{2}{3x}(3+x)$$

$$\Rightarrow x = 2 \Omega$$

28. A radioactive element ${}_{92}^{242}\text{X}$ emits two α -particles, one electron and two positrons. The product nucleus is represented by ${}_{\text{P}}^{234}\text{Y}$. The value of P is _____.

Answer (87)

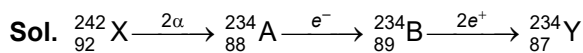

$$\text{So, } P = 87$$

29. A tennis ball is dropped on to the floor from a height of 9.8 m. It rebounds to a height 5.0 m. Ball comes in contact with the floor for 0.2 s. The average acceleration during contact is _____ ms^{-2} .

$$\text{(Given } g = 10 \text{ ms}^{-2}\text{)}$$

Answer (120)

- Sol.** The speed of ball just before collision with ground is $u = \sqrt{2 \times gH} = \sqrt{2 \times 10 \times 9.8} = 14 \text{ m/sec}$
(Downwards)

The speed of ball just after collision is

$$v = \sqrt{2gh} = \sqrt{2 \times 10 \times 5} = 10 \text{ m/sec}$$

(Upwards)

$$\text{So, } \bar{a} = \frac{\Delta v}{\Delta t}$$

$$= \frac{10 + 14}{0.2} = 120 \text{ m/s}^2$$

30. A body cools from 60°C to 40°C in 6 minutes. If, temperature of surroundings is 10°C . Then, after the next 6 minutes, its temperature will be _____ $^\circ\text{C}$.

Answer (28)

Sol. $\frac{\Delta T}{\Delta t} = -k(T_{\text{av}} - T_0)$

Case 1:

$$\frac{-20}{6} = -k(50 - 10)$$

$$\frac{10}{3} = 40k$$

$$k = \frac{1}{12}$$

Case 2:

$$\frac{40 - T}{6} = \frac{1}{12} \left(\frac{40 + T}{2} - 10 \right)$$

$$80 - 2T = \frac{20 + T}{2}$$

$$160 - 4T = 20 + T$$

$$\Rightarrow T = \frac{140}{5}^\circ\text{C} = 28^\circ\text{C}$$

CHEMISTRY**SECTION – A**

Multiple Choice Questions: This section contains 20 multiple choice questions. Each question has 4 choices (1), (2), (3) and (4), out of which **ONLY ONE** is correct.

Choose the correct answer :

31. The correct order of hydration enthalpies is

- (A) K^+ (B) Rb^{+P}
 (C) Mg^{2+} (D) Cs^+
 (E) Ca^{2+}

Choose the correct answer from the options given below:

- (1) $E > C > A > B > D$ (2) $C > E > A > D > B$
 (3) $C > A > E > B > D$ (4) $C > E > A > B > D$

Answer (4)

Sol. Hydration enthalpy \propto charge density

\therefore The correct order of charge density is
 $Mg^{2+} > Ca^{2+} > K^+ > Rb^+ > Cs^+$

\therefore The order of hydration enthalpy
 $C > E > A > B > D$

32. Number of cyclic tripeptides formed with 2 amino acids A and B is:

- (1) 3 (2) 2
 (3) 4 (4) 5

Answer (2)

Sol. The cyclic tripeptides possible with amino acids A and B will be

AAB, BBA

There are only two possibilities.

33. Which of the given compounds can enhance the efficiency of hydrogen storage tank?

- (1) Li/P_4
 (2) $NaNi_5$
 (3) SiH_4
 (4) Di-isobutylaluminium hydride

Answer (2)

Sol. Tanks of metal alloy like $NaNi_5$, $Ti-TiH_2$, $Mg-MgH_2$ are used for the storage of dihydrogen.

34. Match List I with List II.

List I	List II
Antimicrobials	Names
(A) Narrow spectrum antibiotic	(I) Furacin
(B) Antiseptic	(II) Sulphur dioxide
(C) Disinfectants	(III) Penicillin G
(D) Broad spectrum antibiotic	(IV) Chloramphenicol

Choose the correct answer from the options given below:

- (1) (A)-II, (B)-I, (C)-IV, (D)-III
 (2) (A)-III, (B)-I, (C)-II, (D)-IV
 (3) (A)-III, (B)-I, (C)-IV, (D)-II
 (4) (A)-I, (B)-II, (C)-IV, (D)-III

Answer (2)

Sol. Narrow spectrum antibiotic \rightarrow Penicillin G

Antiseptic \rightarrow Furacin

Disinfectants \rightarrow Sulphur dioxide

Broad spectrum antibiotic \rightarrow chloramphenicol

\therefore Correct matching is:

A \rightarrow III, B \rightarrow I, C \rightarrow II, D \rightarrow IV

35. During the borax bead test with $CuSO_4$, a blue green colour of the bead was observed in oxidising flame due to the formation of

- (1) CuO (2) $Cu(BO_2)_2$
 (3) Cu_3B_2 (4) Cu

Answer (2)

Sol. When borax is heated in a Bunsen burner flame with CuO on loop of platinum wire, a blue coloured $Cu(BO_2)_2$ bead is formed

36. The major product 'P' for the following sequence of reactions is :

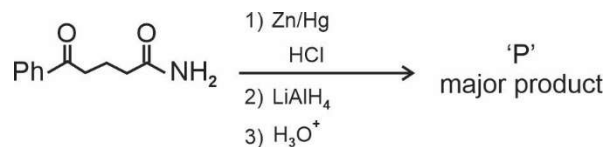

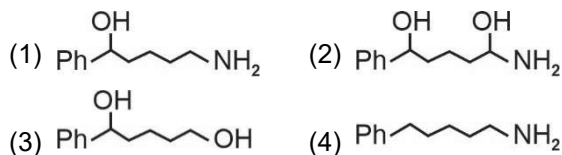

Answer (4)

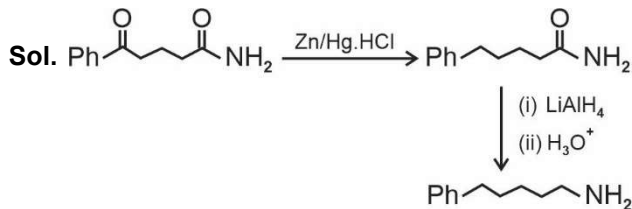

37. Identify the correct order for the given property for following compounds.

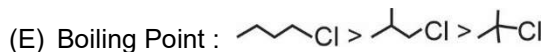
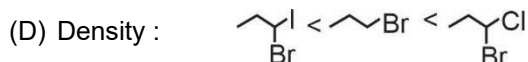
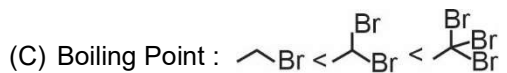
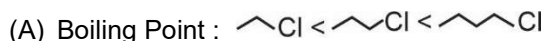

Choose the correct answer from the option given below :

- (1) (A), (C) and (E) only (2) (A), (B) and (E) only
 (3) (A), (C) and (D) only (4) (B), (C) and (D) only

Answer (1)

Sol. → As mass of the compound increases then their boiling point will also increase. Therefore 'A', 'C' are correct.

→ As branching of the compound increases then boiling point decreases. Therefore 'E' is correct.

Density of Et-Cl → 0.89 g/ml

Et-Br → 1.47 g/ml

Et-I → 1.94 g/ml

∴ Option 'B' is incorrect

* No option contains correct option

A, C and E are correct

38. "A" obtained by Ostwald's method involving air oxidation of NH_3 , upon further air oxidation produces "B". "B" on hydration forms an oxoacid of Nitrogen along with evolution of "A". The oxoacid also produces "A" and gives positive brown ring test.

Identify A and B, respectively.

- (1) NO , NO_2 (2) N_2O_3 , NO_2
 (3) NO_2 , N_2O_4 (4) NO_2 , N_2O_5

Answer (1)

Sol. Ostwald's process is :

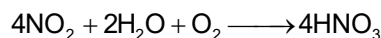
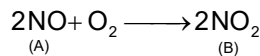
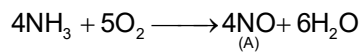

∴ A and B are NO and NO_2 respectively

39. The standard electrode potential ($\text{M}^{3+}/\text{M}^{2+}$) for V, Cr, Mn & Co are -0.26 V, -0.41 V, $+1.57$ V and $+1.97$ V, respectively. The metal ions which can liberate H_2 from a dilute acid are

- (1) V^{2+} and Cr^{2+}
 (2) V^{2+} and Mn^{2+}
 (3) Cr^{2+} and Co^{2+}
 (4) Mn^{2+} and Co^{2+}

Answer (1)

Sol. E° of H^+/H_2 is zero

∴ The metals having less reduction potential can produce H_2 gas with dilute acid.

∴ V and Cr metal can produce H_2 gas

40. Match List I with List II

List I	List II
Reaction	Reagents
(A) Hoffmann Degradation	(I) Conc.KOH, Δ
(B) Clemenson reduction	(II) CHCl_3 , NaOH/ $\text{H}_3\text{O}^{\oplus}$
(C) Cannizaro reaction	(III) Br_2 , NaOH
(D) Reimer-Tiemann Reaction	(IV) Zn-Hg/HCl

Choose the correct answer from the option given below :

- (1) (A)-III, (B) -IV, (C) – II, (D)-I
 (2) (A)-III, (B) -IV, (C) –I, (D)-II
 (3) (A)-II, (B) -IV, (C) –I, (D)-III
 (4) (A)-II, (B) -I, (C) – III, (D)-IV

Answer (2)

Sol.

	Reaction		Reagents
(A)	Hoffmann degradation	→	Br ₂ , NaOH
(B)	Clemenson reduction	→	Zn-Hg/HCl
(C)	Cannizaro-reaction	→	Conc. KOH, Δ
(D)	Reimer-Tiemann reaction	→	CHCl ₃ , NaOH/H ₃ O ⁺

∴ Correct match is :

(A)-III, (B) -IV, (C) -I, (D)-II

 41. The magnetic behavior of Li₂O, Na₂O₂ and KO₂, respectively, are

- (1) Paramagnetic, paramagnetic and diamagnetic
- (2) Diamagnetic, diamagnetic and paramagnetic
- (3) Paramagnetic, diamagnetic and paramagnetic
- (4) Diamagnetic, paramagnetic and diamagnetic

Answer (2)
Sol. Li₂O → diamagnetic

 Na₂O₂ → diamagnetic

 KO₂ → paramagnetic (as O₂⁻ is para magnetic)

42. The bond dissociation energy is highest for

- (1) Cl₂
- (2) I₂
- (3) F₂
- (4) Br₂

Answer (1)
Sol. Bond dissociation energy of Cl₂ is highest among the halogen.

 43. The shortest wavelength of hydrogen atom in Lyman series is λ. The longest wavelength in Balmer series of He⁺ is

- (1) $\frac{5}{9\lambda}$
- (2) $\frac{5\lambda}{9}$
- (3) $\frac{36\lambda}{5}$
- (4) $\frac{9\lambda}{5}$

Answer (4)
Sol. $\frac{hc}{\lambda} = 13.6$ (i)

For longest wavelength in Balmer series transition will be 3 → 2

$$\therefore \Delta E = 13.6 \times 2^2 \times \left(\frac{1}{4} - \frac{1}{9} \right)$$

$$= 13.6 \times 4 \times \frac{5}{4 \times 9}$$

$$\frac{hc}{\lambda^1} = 13.6 \times \frac{5}{9}$$

$$\therefore \lambda^1 = \frac{9}{5} \lambda$$

44. The reaction representing the Mond process for metal refining is _____.

- (1) $Zr + 2I_2 \xrightarrow{\Delta} ZrI_4$
- (2) $Ni + 4CO \xrightarrow{\Delta} Ni(CO)_4$
- (3) $ZnO + C \xrightarrow{\Delta} Zn + CO$
- (4) $2K[Au(CN)_2] + Zn \xrightarrow{\Delta} K_2[Zn(CN)_4] + 2Au$

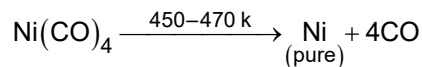
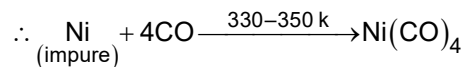
Answer (2)
Sol. Mond process is need for the purification of Ni metal

45. Chiral complex from the following is

Here en = ethylene diamine

- (1) trans - [Co(NH₃)₄Cl₂]⁺
- (2) cis - [PtCl₂(en)₂]²⁺
- (3) cis - [PtCl₂(NH₃)₂]
- (4) trans - [PtCl₂(en)₂]²⁺

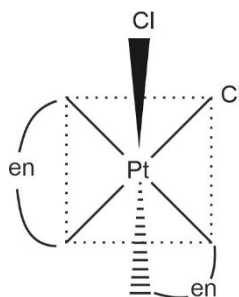
Answer (2)
Sol. Cis - [Pt Cl₂(en)₂]²⁺

has no any element of symmetry so it is optically active.

46. Compound that will give positive Lassaigne's test for both nitrogen and halogen is
 (1) $\text{CH}_3\text{NH}_2 \cdot \text{HCl}$ (2) $\text{NH}_2\text{OH} \cdot \text{HCl}$
 (3) NH_4Cl (4) $\text{N}_2\text{H}_4 \cdot \text{HCl}$

Answer (1)

Sol. $\text{CH}_3\text{NH}_2 \cdot \text{HCl}$ will give positive Lassaigne's test for both nitrogen and halogen.

47. Which of the following salt solutions would coagulate the colloid solution formed when FeCl_3 is added to NaOH solution, at the fastest rate?
 (1) 10 mL of $0.1 \text{ mol dm}^{-3} \text{ Ca}_3(\text{PO}_4)_2$
 (2) 10 mL of $0.2 \text{ mol dm}^{-3} \text{ AlCl}_3$
 (3) 10 mL of $0.1 \text{ mol dm}^{-3} \text{ Na}_2\text{SO}_4$
 (4) 10 mL of $0.15 \text{ mol dm}^{-3} \text{ CaCl}_2$

Answer (2)

Sol. In the coagulation of a negative sol, the flocculating power is in the order.

$\therefore \text{Al}^{3+} > \text{Ba}^{2+} > \text{Na}^+$ and FeCl_3 with NaOH forms a negative sol.

$\therefore \text{AlCl}_3$ coagulate it most.

48. The increasing order of pK_a for the following phenols is
 (A) 2,4-Dinitrophenol
 (B) 4-Nitrophenol
 (C) 2,4,5-Trimethylphenol
 (D) Phenol
 (E) 3-Chlorophenol

Choose the correct answer from the option given below :

- (1) (C), (E), (D), (B), (A) (2) (C), (D), (E), (B), (A)
 (3) (A), (E), (B), (D), (C) (4) (A), (B), (E), (D), (C)

Answer (4)

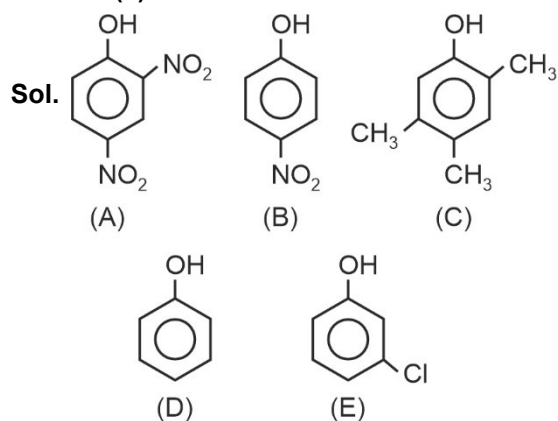

Their acidic order is $A > B > E > D > C$.

\therefore Their pK_a value is $A < B < E < D < C$.

49. Correct statement about smog is
 (1) NO_2 is present in classical smog
 (2) Classical smog also has high concentration of oxidizing agents
 (3) Photochemical smog has high concentration of oxidizing agents
 (4) Both NO_2 and SO_2 are present in classical smog

Answer (3)

- Sol.** • Classical smog occurs in cool humid climate. It is a mixture of smoke, fog and sulphur dioxide. Chemically, it is a reducing mixture and so it is also called as reducing smog.
 • Photochemical smog has high concentration of oxidising agents.

50. For 1 mol of gas, the plot of pV vs. p is shown below. p is the pressure and V is the volume of the gas.

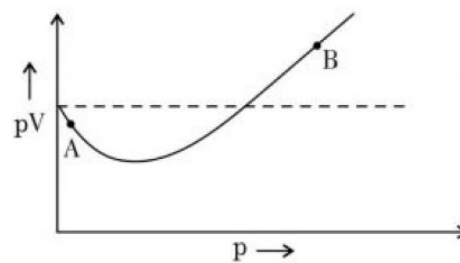

What is the value of compressibility factor at point A?

- (1) $1 - \frac{a}{RTV}$ (2) $1 + \frac{b}{V}$
 (3) $1 - \frac{b}{V}$ (4) $1 + \frac{a}{RTV}$

Answer (1)

Sol. At point 'A', 'a' is considerable and 'b' is negligible.

$$\therefore \left(p + \frac{a}{V^2} \right) V = RT$$

$$pV + \frac{a}{V} = RT$$

$$Z = 1 - \frac{a}{VRT}$$

SECTION - B

Numerical Value Type Questions: This section contains 10 questions. In Section B, attempt any five questions out of 10. The answer to each question is a **NUMERICAL VALUE**. For each question, enter the correct numerical value (in decimal notation, truncated/rounded-off to the second decimal place; e.g. 06.25, 07.00, -00.33, -00.30, 30.27, -27.30) using the mouse and the on-screen virtual numeric keypad in the place designated to enter the answer.

51. Millimoles of calcium hydroxide required to produce 100 mL of the aqueous solution of pH 12 is $x \times 10^{-1}$. The value of x is _____ (Nearest integer).

Answer (05.00)

Sol. pH = 12

$$\therefore [\text{OH}^-] = 10^{-2}$$

$$\frac{\text{milli mole of Ca(OH)}_2 \times 2}{100} = 10^{-2}$$

$$\therefore \text{milli moles of Ca(OH)}_2 \text{ required} = 5 \times 10^{-1}$$

52. Solid Lead nitrate is dissolved in 1 litre of water. The solution was found to boil at 100.15°C . When 0.2 mol of NaCl is added to the resulting solution, it was observed that the solution froze at -0.8°C . The solubility product of PbCl_2 formed is _____ $\times 10^{-6}$ at 298 K. (Nearest integer)

Given : $K_b = 0.5 \text{ K kg mol}^{-1}$ and $K_f = 1.8 \text{ K kg mol}^{-1}$. Assume molality to be equal to molarity in all cases.

Answer (13.00)

Sol. $0.15 = 3 \times 0.5 \times M$

$$M_{\text{Pb(NO}_3)_2} = 0.1 \text{ molar}$$

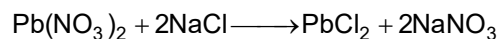

$$\Delta T_f = iK_f \cdot m$$

$$0.8 = (0.4 + 3s) 1.8$$

$$s = 0.0148$$

$$\begin{aligned} \therefore \text{solubility product} &= 4s^3 \\ &= 4 \times (0.0148)^3 \\ &\approx 13 \times 10^{-6} \end{aligned}$$

53. Water decomposes at 2300 K

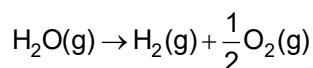

The percent of water decomposing at 2300 K and 1 bar is _____ (Nearest integer).

Equilibrium constant for the reaction is 2×10^{-3} at 2300 K.

Answer (02)

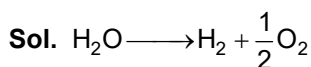

$$K_p = \frac{P_T^{\frac{3}{2}} \left(1 + \frac{\alpha}{2}\right) \alpha^{\frac{3}{2}}}{2^{\frac{1}{2}} P_T \left(1 + \frac{\alpha}{2}\right)^{\frac{3}{2}} (1 - \alpha)}$$

$$2 \times 10^{-3} = \frac{\alpha^{\frac{3}{2}}}{2^{\frac{1}{2}}} \text{ [as } \alpha \ll 1 \text{ and let } P_T = 1]$$

$$\begin{aligned} \alpha^{\frac{3}{2}} &= 2^{\frac{1}{2}} \times 10^{-3} \\ &\approx 2 \times 10^{-2} \end{aligned}$$

$$\therefore \% \text{ of water decomposition} = 2\%$$

54. The number of molecules or ions from the following, which do not have odd number of electrons are _____.

- (A) NO_2 (B) ICl_4^-
(C) BrF_3 (D) ClO_2
(E) NO_2^+ (F) NO

Answer (03.00)

Sol. The odd electronic species are :

$\text{NO}_2, \text{ClO}_2, \text{NO}$

55. Following figure shows dependence of molar conductance of two electrolytes on concentration. Λ_m° is the limiting molar conductivity.

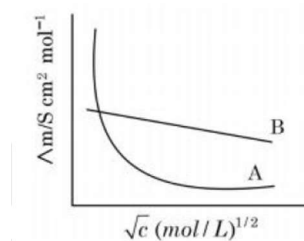

The number of **incorrect** statement(s) from the following is _____

- (A) Λ_m° for electrolyte A is obtained by extrapolation.
(B) For electrolyte B, Λ_m vs \sqrt{c} graph is a straight line with intercept equal to Λ_m°
(C) At infinite dilution, the value of degree of dissociation approaches zero for electrolyte B.
(D) Λ_m° for any electrolyte A or B can be calculated using λ° for individual ions.

Answer (02.00)

Sol. (A) Λ_m° for 'A' cannot be obtained by extra polation.

(C) At infinite dilution, value of degree of dissociation approaches one.

\therefore A and C are incorrect

56. For certain chemical reaction $X \rightarrow Y$, the rate of formation of product is plotted against the time as shown in the figure. The number of **correct** statement/s from the following is _____

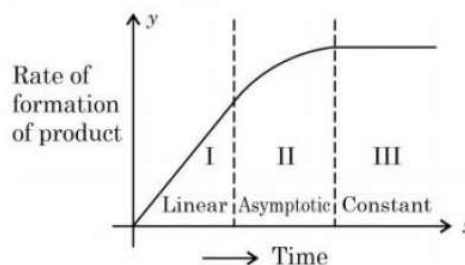

- (A) Over all order of this reaction is one
 (B) Order of this reaction can't be determined
 (C) In region I and III, the reaction is of first and zero order respectively
 (D) In region-II, the reaction is of first order
 (E) In region-II, the order of reaction is in the range of 0.1 to 0.9.

Answer (02.00)

Sol. Either the order w.r.t. reaction is negative in region I and II or the order of the reaction depends only on the concentration of product. So by that reasoning if order of the reaction depends only on the concentration of product then statement C and E are correct.

57. The sum of bridging carbonyls in $W(CO)_6$ and $Mn_2(CO)_{10}$ is _____.

Answer (00.00)

Sol. $W(CO)_6$

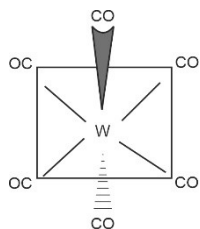

$Mn_2(CO)_{10}$

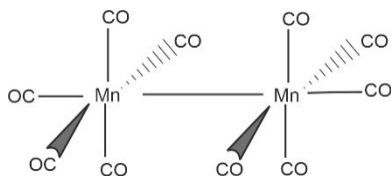

therefor there are no any bridging carbonyl are present.

58. Following chromatogram was developed by adsorption of compound 'A' on a 6 cm TLC glass plate. Retardation factor of the compound 'A' is _____ $\times 10^{-1}$.

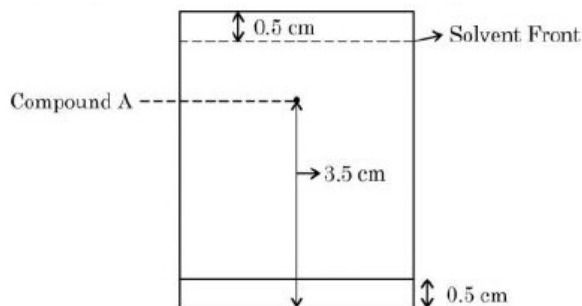

Answer (06.00)

Sol. Retardation factor = $\frac{3}{5} = 0.6 = 6 \times 10^{-1}$

59. Consider the following reaction approaching equilibrium at 27°C and 1 atm pressure

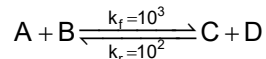

The standard Gibb's energy change ($\Delta_r G^\circ$) at 27°C is (-) _____ kJ mol^{-1}

(Nearest integer).

(Given : $R = 8.3 \text{ J K}^{-1} \text{ mol}^{-1}$ and $\ln 10 = 2.3$)

Answer (06.00)

Sol. $\Delta G = -RT \ln(k_{eq})$

$$k_{(eq)} = \frac{k_f}{k_r} = 10$$

$$\Delta G = -8.3 \times 300 \times \ln(10)$$

$$= -8.3 \times 300 \times 2.3$$

$$= -5.727 \text{ kJ/mol}$$

$$\approx -6 \text{ kJ/mol}$$

60. 17 mg of a hydrocarbon (M.F. $C_{10}H_{16}$) takes up 8.40 mL of the H_2 gas measured at 0°C and 760 mm of Hg. Ozonolysis of the same hydrocarbon yields

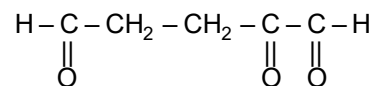
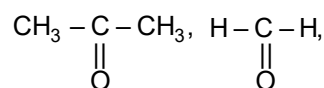

The number of double bond/s present in the hydrocarbon is _____

Answer (03.00)

Sol. $C_{10}H_{16} + H_2 \longrightarrow$

$$\frac{17 \times 10^{-3}}{136} \qquad \frac{1 \times 8.4 \times 10^{-3}}{0.082 \times 273}$$

0.125 milli moles 0.375 milli moles

0.125 milli moles of $C_{10}H_{16}$ required 0.375 milli moles of H_2 therefore there are total 3 π -bonds.

\therefore DOU will also be equal to 3

MATHEMATICS

SECTION - A

Multiple Choice Questions: This section contains 20 multiple choice questions. Each question has 4 choices (1), (2), (3) and (4), out of which **ONLY ONE** is correct.

Choose the correct answer :

61. Let $[x]$ denote the greatest integer $\leq x$. Consider the function $f(x) = \max\{x^2, 1 + [x]\}$. Then the value of the integral $\int_0^2 f(x) dx$ is

- (1) $\frac{1+5\sqrt{2}}{3}$ (2) $\frac{5+4\sqrt{2}}{3}$
 (3) $\frac{8+4\sqrt{2}}{3}$ (4) $\frac{4+5\sqrt{2}}{3}$

Answer (2)

Sol.

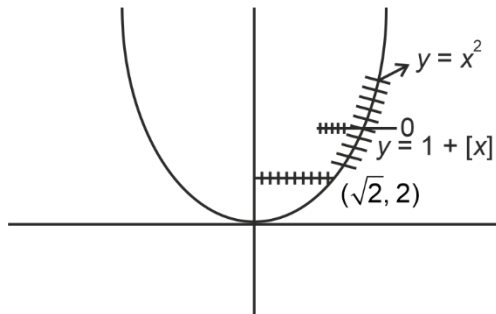

$$\therefore f(x) = 1 \quad x \in [0, 1)$$

$$2 \quad x \in [1, \sqrt{2})$$

$$x^2 \quad x \in [\sqrt{2}, 2]$$

$$\therefore \int_0^2 f(x) dx = \int_0^1 1 dx + \int_1^{\sqrt{2}} 2 dx + \int_{\sqrt{2}}^2 x^2 dx$$

$$= 1 + 2\sqrt{2} - 2 + \frac{x^3}{3} \Big|_{\sqrt{2}}^2$$

$$= 2\sqrt{2} - 1 + \frac{8}{3} - \frac{2\sqrt{2}}{3}$$

$$= \frac{5+4\sqrt{2}}{3}$$

62. Let the tangents at the points $A(4, -11)$ and $B(8, -5)$ on the circle $x^2 + y^2 - 3x + 10y - 15 = 0$, intersect at the point C . Then the radius of the circle, whose centre is C and the line joining A and B is its tangent, is equal to

- (1) $\sqrt{13}$
 (2) $\frac{3\sqrt{3}}{4}$
 (3) $\frac{2\sqrt{13}}{3}$
 (4) $2\sqrt{13}$

Answer (3)

Sol.

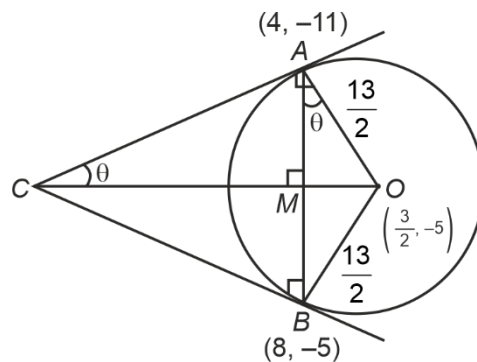

$$OA = OB = \frac{13}{2}$$

$$\therefore AB = 2\sqrt{13} \text{ then } AM = \sqrt{13}$$

In $\triangle AMO$: $\angle OAM = \theta = \angle ACO$

$$\therefore OC = \frac{13}{2 \sin \theta}$$

$$\therefore \sin \theta = \frac{3\sqrt{13}}{13} = \frac{3}{\sqrt{13}}$$

$$\therefore OC = \frac{13\sqrt{13}}{6}$$

and $OM = \frac{3\sqrt{13}}{2}$

$$\therefore CM = OC - OM = \frac{2\sqrt{13}}{3}$$

63. Let $A = \{(x, y) \in \mathbb{R}^2 : y \geq 0, 2x \leq y \leq \sqrt{4 - (x-1)^2}\}$

and

$B = \{(x, y) \in \mathbb{R} \times \mathbb{R} : 0 \leq y \leq \min\{2x, \sqrt{4 - (x-1)^2}\}\}$.

Then the ratio of the area of A to the area of B is

- (1) $\frac{\pi}{\pi-1}$ (2) $\frac{\pi+1}{\pi-1}$
 (3) $\frac{\pi-1}{\pi+1}$ (4) $\frac{\pi}{\pi+1}$

Answer (3)

Sol. For A:

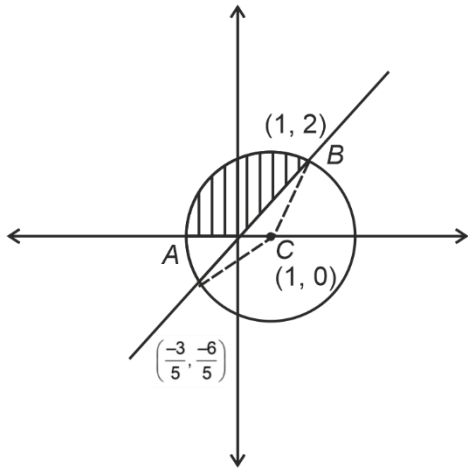

For B:

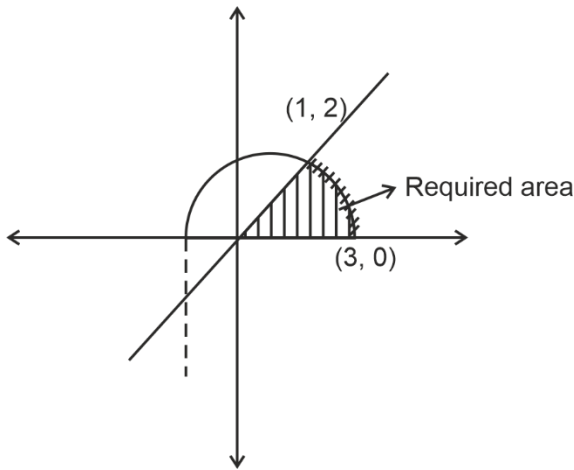

Area (A) + Area (B) = 2π

Area B = $\int_0^1 2x dx + \int_1^3 \sqrt{4 - (x-1)^2} dx$

$= 1 + \frac{\pi 4}{4} = \pi + 1$

Area A = $\pi - 1$

\therefore Required ratio = $\frac{\pi-1}{\pi+1}$

64. Let α and β be real numbers. Consider a 3×3 matrix A such that $A^2 = 3A + \alpha I$. If $A^4 = 21A + \beta I$, then

- (1) $\alpha = 1$ (2) $\alpha = 4$
 (3) $\beta = 8$ (4) $\beta = -8$

Answer (4)

Sol. $A^4 = A^2 A^2$

$= (3A + \alpha I)(3A + \alpha I)$

$= 9A^2 + 6\alpha A + \alpha^2 I$

$= 9(3A + \alpha I) + 6\alpha A + \alpha^2 I$

$= (27 + 6\alpha)A + (9\alpha + \alpha^2)I = 21A + \beta I$

$\Rightarrow \alpha = -1, \beta = -8$

65. Let $f(\theta) = 3\left(\sin^4\left(\frac{3\pi}{2} - \theta\right) + \sin^4(3\pi + \theta)\right) - 2(1 - \sin^2 2\theta)$

and $S = \left\{ \theta \in [0, \pi] : f'(\theta) = -\frac{\sqrt{3}}{2} \right\}$. If $4\beta = \sum_{\theta \in S} \theta$,

then $f(\beta)$ is equal to

- (1) $\frac{9}{8}$ (2) $\frac{3}{2}$
 (3) $\frac{5}{4}$ (4) $\frac{11}{8}$

Answer (3)

Sol. $f(\theta) = 3(\cos^4\theta + \sin^4\theta) - 2(1 - \sin^2 2\theta)$

$f'(\theta) = 12(\cos^3\theta(-\sin\theta) + \sin^3\theta \cos\theta) + 4 \sin 4\theta$

$= 12(\cos\theta \sin\theta(-\cos 2\theta)) + 4 \sin 4\theta$

$= -6 \sin 2\theta \cos 2\theta + 4 \sin 4\theta$

$= -3 \sin 4\theta + 4 \sin 4\theta$

$= \sin 4\theta$

$\sin 4\theta = -\frac{\sqrt{3}}{2}$

$4\theta = \left\{ \frac{3\pi}{2} - \frac{\pi}{3}, \frac{3\pi}{2} + \frac{\pi}{3}, \frac{7\pi}{2} - \frac{\pi}{3}, \frac{7\pi}{2} + \frac{\pi}{3} \right\}$

$\sum \theta = \frac{5\pi}{2} \Rightarrow \beta = \frac{5\pi}{8}$

$f(\theta) = 3(1 - 2\sin^2\theta + \cos^2\theta) - 2\cos^2 2\theta$

$= 3\left(1 - \frac{1}{2}\sin^2 \frac{5\pi}{4}\right) - 2\cos^2 \frac{5\pi}{4}$

$= 3\left(1 - \frac{1}{4}\right) - 2 \cdot \frac{1}{2} = \frac{5}{4}$

66. Consider the following system of equations

$$\alpha x + 2y + z = 1$$

$$2\alpha x + 3y + z = 1$$

$$3x + \alpha y + 2z = b$$

For some $\alpha, \beta \in \mathbb{R}$. then which of the following is NOT correct?

- (1) It has no solution if $\alpha = -1$ and $\beta \neq 2$
- (2) It has a solution for all $\alpha \neq -1$ and $\beta = 2$
- (3) It has no solution for $\alpha = 3$ and for all $\beta \neq 2$
- (4) It has no solution for $\alpha = -1$ and for all $\beta \in \mathbb{R}$.

Answer (3)

Sol.
$$\begin{vmatrix} \alpha & 2 & 1 \\ 2\alpha & 3 & 1 \\ 3 & \alpha & 2 \end{vmatrix} = 0$$

$$\alpha(6 - \alpha) - 2(4\alpha - 3) + 1(2\alpha^2 - 9) = 0$$

$$\Rightarrow 6\alpha - \alpha^2 - 8\alpha + 6 + 2\alpha^2 - 9 = 0$$

$$\Rightarrow \alpha^2 - 2\alpha - 3 = 0$$

OR $\alpha = 3, -1$

For $\alpha = 3, \beta = 2 \Rightarrow$ Infinite solution

For $\alpha = -1, \beta = 2 \Rightarrow$ Infinite solution

For $\alpha = -1, \beta \neq 2 \Rightarrow$ no solution

67. Let $f(x) = x + \frac{a}{\pi^2 - 4} \sin x + \frac{b}{\pi^2 - 4} \cos x, x \in \mathbb{R}$ be a function which satisfies

$$f(x) = x + \int_0^{\pi/2} \sin(x+y)f(y)dy. \text{ Then } (a + b) \text{ is}$$

equal to

- (1) $-\pi(\pi + 2)$
- (2) $-\pi(\pi - 2)$
- (3) $-2\pi(\pi + 2)$
- (4) $-2\pi(\pi - 2)$

Answer (3)

Sol. $\therefore f(x) = x + \frac{a}{\pi^2 - 4} \sin x + \frac{b}{\pi^2 - 4} \cos x, x \in \mathbb{R}$

And $f(x) = x + \int_0^{\pi/2} \sin(x+y)f(y)dy$

$$\Rightarrow f(x) = x + \left(\int_0^{\pi/2} f(y) \cdot \cos y dy \right) \sin x + \left(\int_0^{\pi/2} f(y) \sin y dy \right) \cos x$$

$$\therefore \frac{a}{\pi^2 - 4} = \int_0^{\pi/2} \cos y \left(y + \frac{a}{\pi^2 - 4} \sin y + \frac{b}{\pi^2 - 4} \cos y \right) dy$$

$$\frac{a}{\pi^2 - 4} = \frac{\pi}{2} - 1 + \frac{a}{2(\pi^2 - 4)} + \frac{b\pi}{4(\pi^2 - 4)}$$

$$\therefore 2a - b\pi = 2(\pi + 2)(\pi - 2)^2 \dots(i)$$

$$\text{and } \frac{b}{\pi^2 - 4} = \int_0^{\pi/2} \left(y + \frac{a}{\pi^2 - 4} \sin y + \frac{b}{\pi^2 - 4} \cos y \right) \sin y dy$$

$$\frac{b}{\pi^2 - 4} = 1 + \frac{a\pi}{4(\pi^2 - 4)} + \frac{b}{2(\pi^2 - 4)}$$

$$\therefore a\pi - 2b = -4(\pi^2 - 4) \dots(ii)$$

Equation (i) – equation (ii)

$$(2 - \pi)(a + b) = 2(\pi^2 - 4)(\pi - 2 + 2)$$

$$\therefore a + b = -2\pi(\pi + 2)$$

68. Fifteen football players of a club-team are given 15 T-shirts with their names written on the backside. If the players pick up the T-shirts randomly, then the probability that at least 3 players pick the correct T-shirt is

- (1) $\frac{1}{6}$
- (2) $\frac{5}{36}$
- (3) $\frac{2}{15}$
- (4) $\frac{5}{24}$

Answer (*)

69. If p, q and r are three propositions, then which of the following combination of truth values of p, q and r makes the logical expression $\{(p \vee q) \wedge ((\neg p) \vee r)\} \rightarrow ((\neg q) \vee r)$ false ?

- (1) $p = F, q = T, r = F$
- (2) $p = T, q = F, r = T$
- (3) $p = T, q = T, r = F$
- (4) $p = T, q = F, r = F$

Answer (1)

Sol.

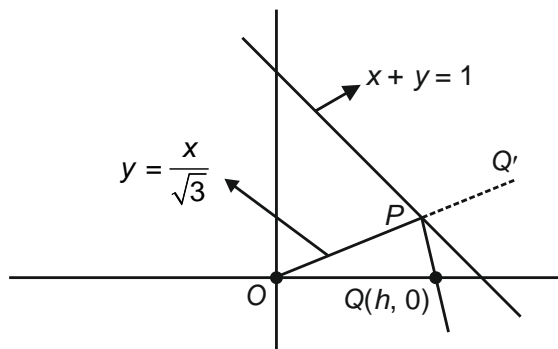

Let $Q(h, 0)$

$\therefore OP$ reflected by $x + y = 1$.

So, image of Q lies on $y = \frac{x}{\sqrt{3}}$

$$\therefore \frac{x-h}{1} = \frac{y}{1} = \frac{-2(h-1)}{2}$$

$$\therefore x = 1, y = 1 - h$$

It lies on $y = \frac{x}{\sqrt{3}}$

$$\therefore 1 - h = \frac{1}{\sqrt{3}}$$

$$\therefore h = 1 - \frac{1}{\sqrt{3}} = \frac{\sqrt{3} - 1}{\sqrt{3}} = \frac{2}{3 + \sqrt{3}}$$

Option (2) is correct.

74. Let Δ be the area of the region

$$\{(x, y) \in \mathbb{R}^2 : x^2 + y^2 \leq 21, y^2 \leq 4x, x \geq 1\}.$$
 Then

$$\frac{1}{2} \left(\Delta - 21 \sin^{-1} \left(\frac{2}{\sqrt{7}} \right) \right)$$
 is equal to

(1) $\sqrt{3} - \frac{4}{3}$ (2) $2\sqrt{3} - \frac{1}{3}$

(3) $\sqrt{3} - \frac{2}{3}$ (4) $2\sqrt{3} - \frac{2}{3}$

Answer (1)

Sol.

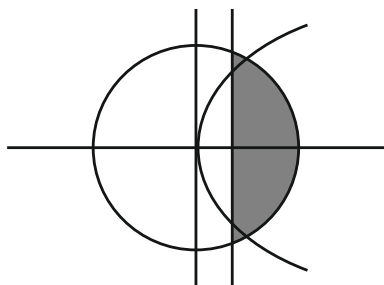

$$\begin{aligned} \text{Required area} &= 2 \int_1^3 2\sqrt{x} \, dx + \int_3^{\sqrt{21}} \sqrt{(21-x^2)} \, dx \\ &= 2 \left(\left[2 \left(\frac{x^{3/2}}{3/2} \right) \right]_1^3 + \left[\frac{x}{2} \sqrt{21-x^2} + \frac{21}{2} \sin^{-1} \left(\frac{x}{\sqrt{21}} \right) \right]_3^{\sqrt{21}} \right) \\ &= 2\sqrt{3} + \frac{21\pi}{2} - \frac{8}{3} - 21 \sin^{-1} \left(\frac{\sqrt{3}}{7} \right) = \Delta \\ \therefore \frac{1}{2} \left(\Delta - 21 \sin^{-1} \left(\frac{2}{\sqrt{7}} \right) \right) &= \frac{\sqrt{3} - 4}{3} \end{aligned}$$

Option (1) is correct.

75. The domain of $f(x) = \frac{\log_{(x+1)}(x-2)}{e^{2 \log_e x} - (2x+3)}$, $x \in \mathbb{R}$ is

- (1) $\mathbb{R} - \{-1, 3\}$ (2) $(-1, \infty) - \{3\}$
 (3) $\mathbb{R} - \{3\}$ (4) $(2, \infty) - \{3\}$

Answer (4)

Sol. $f(x) = \frac{\log_{x+1}(x-2)}{e^{2 \ln x} - (2x+3)}$

- (i) $x - 2 > 0 \Rightarrow x > 2$
 (ii) $x + 1 > 0 \Rightarrow x > -1$ and $x \neq -1$
 (iii) $x > 0$
 (iv) $x^2 - 2x - 3 \neq 0$
 $\Rightarrow (x - 3)(x + 1) \neq 0$
 $\Rightarrow x \neq -1, 3$
 (i) \cap (ii) \cap (iii) \cap (iv)
 $x \in (2, \infty) - \{3\}$

76. Let $f : \mathbb{R} \rightarrow \mathbb{R}$ be a function such that

$$f(x) = \frac{x^2 + 2x + 1}{x^2 + 1}.$$
 Then

- (1) $f(x)$ is many-one in $(-\infty, -1)$
 (2) $f(x)$ is one-one in $[1, \infty)$ but not in $(-\infty, \infty)$
 (3) $f(x)$ is many-one in $(1, \infty)$
 (4) $f(x)$ is one-one in $(-\infty, \infty)$

Answer (2)

Sol. $f(x) = \frac{x^2 + 2x + 1}{x^2 + 1}$, where $f : \mathbb{R} \rightarrow \mathbb{R}$

$$= \frac{(x+1)^2}{x^2 + 1} \geq 0$$

$$f'(x) = \frac{(x^2 + 1)(2x + 2) - (x^2 - 2x + 1)(2x)}{(x^2 + 1)^2}$$

$$= \frac{2(x + 1)(x^2 + 1) - (x + 1)^2(2x)}{(x^2 + 1)^2}$$

$$\Rightarrow 2(x + 1)(x^2 + 1 - (x + 1)x) = 0$$

$$\Rightarrow 2(x + 1)(x - 1) = 0$$

$$\Rightarrow x = 1, -1 \Rightarrow \text{points of minima and maxima}$$

77. Let $y = f(x)$ be the solution of the differential equation $y(x + 1)dx - x^2 dy = 0$, $y(1) = e$. Then

$\lim_{x \rightarrow 0} f(x)$ is equal to

(1) $\frac{1}{e}$ (2) 0

(3) $\frac{1}{e^2}$ (4) e^2

Answer (2)

Sol. $y(x + 1)dx = x^2 dy$

$$\Rightarrow \left(\frac{x+1}{x^2}\right) dx = \frac{dy}{y}$$

$$\Rightarrow \ln x - \frac{1}{x} = \ln y + c$$

$$x = 1, y = e$$

$$\Rightarrow c = -2$$

$$\Rightarrow \ln y = \ln x - \frac{1}{x} + 2$$

$$y = xe^{2 - \frac{1}{x}}$$

$$\lim_{x \rightarrow 0^+} y = 0 \times e^{-\infty} = 0$$

78. For two non-zero complex numbers z_1 and z_2 , if $\operatorname{Re}(z_1 z_2) = 0$ and $\operatorname{Re}(z_1 + z_2)$, then which of the following are possible?

A. $\operatorname{Im}(z_1) > 0$ and $\operatorname{Im}(z_2) > 0$

B. $\operatorname{Im}(z_1) < 0$ and $\operatorname{Im}(z_2) > 0$

C. $\operatorname{Im}(z_1) > 0$ and $\operatorname{Im}(z_2) < 0$

D. $\operatorname{Im}(z_1) < 0$ and $\operatorname{Im}(z_2) < 0$

Choose the correct answer from the options given below

(1) B and C (2) B and D

(3) A and B (4) A and C

Answer (1)

Sol. Let $z_1 = x_1 + iy_1$

$$z_2 = x_2 + iy_2$$

$$\Rightarrow x_1 x_2 - y_1 y_2 = 0 \quad \dots(i)$$

$$(x_1 + x_2) = 0 \quad \dots(ii)$$

$$x_1^2 + y_1 y_2 = 0$$

$$\Rightarrow y_1 y_2 = -x_1^2$$

$\Rightarrow y_1$ and y_2 have opposite signs.

79. Three rotten apples are mixed accidentally with seven good apples and four apples are drawn one by one without replacement. Let the random variable X denote the number of rotten apples. If μ and σ^2 represent mean and variance of X , respectively, then $10(\mu^2 + \sigma^2)$ is equal to

(1) 25

(2) 250

(3) 30

(4) 20

Answer (4)

x_i	0	1	2	3
Sol. p_i	$\frac{35}{210} = \frac{1}{6}$	$\frac{105}{210} = \frac{1}{2}$	$\frac{3 \times 21}{210} = \frac{3}{10}$	$\frac{7}{210} = \frac{1}{30}$

$$\begin{aligned} \mu &= \sum p_i x_i = \frac{1}{2} + \frac{6}{10} + \frac{21}{210} \\ &= \frac{1}{2} + \frac{3}{5} + \frac{1}{10} \\ &= \frac{6}{5} \end{aligned}$$

$$\begin{aligned} \sigma^2 &= \sum p_i x_i^2 - \mu^2 \\ &= \left(\frac{1}{2} + \frac{4.3}{10} + 9 \cdot \frac{1}{30}\right) - \left(\frac{6}{5}\right)^2 \\ &= \left(\frac{1}{2} + \frac{6}{5} + \frac{3}{10}\right) - \frac{36}{25} \\ &= \frac{14}{25} \end{aligned}$$

Now, $10(\mu^2 + \sigma^2)$

$$= 20$$

80. Let $\lambda \neq 0$ be a real number. Let α, β be the roots of the equation $14x^2 - 31x + 3\lambda = 0$ and α, γ be the roots of the equation $35x^2 - 53x + 4\lambda = 0$. Then $\frac{3\alpha}{\beta}$

and $\frac{4\alpha}{\gamma}$ are the roots of the equation

- (1) $7x^2 + 245x - 250 = 0$
- (2) $49x^2 + 245x + 250 = 0$
- (3) $7x^2 - 245x + 250 = 0$
- (4) $49x^2 - 245x + 250 = 0$

Answer (4)

Sol. $35x^2 - 53x + 4\lambda = 0$... (i)

$(14x^2 - 31x + 3\lambda = 0) \times 2.5$... (ii)

(i) and (ii) gives

$$x = \frac{\lambda}{7} = \alpha$$

$$\alpha\beta = \frac{3\lambda}{14} \Rightarrow \beta = \frac{3\lambda}{14} \cdot \frac{7}{\lambda} = \frac{3}{2}$$

$$\alpha\gamma = \frac{4\lambda}{35} \Rightarrow \gamma = \frac{4}{35} \cdot 7 = \frac{4}{5}$$

$$\alpha + \beta = \frac{31}{14} \Rightarrow \alpha = \frac{5}{7}$$

$$\frac{3\alpha}{\beta} = \frac{10}{7}, \frac{4\alpha}{\gamma} = \frac{20}{7} \cdot \frac{5}{4} = \frac{25}{7}$$

Equation formed will be

$$x^2 - 5x + \frac{250}{49} = 0$$

$$49x^2 - 245x + 250 = 0$$

SECTION - B

Numerical Value Type Questions: This section contains 10 questions. In Section B, attempt any five questions out of 10. The answer to each question is a **NUMERICAL VALUE**. For each question, enter the correct numerical value (in decimal notation, truncated/rounded-off to the second decimal place; e.g. 06.25, 07.00, -00.33, -00.30, 30.27, -27.30) using the mouse and the on-screen virtual numeric keypad in the place designated to enter the answer.

81. Let a_1, a_2, a_3, \dots be a G.P of increasing positive numbers. If the product of fourth and sixth terms is 9 and the sum of fifth and seventh terms is 24, then $a_1 a_9 + a_2 a_4 a_8 + a_5 + a_7$ is equal to _____.

Answer (60)

Sol. Let r be the common ratio of the G.P

$$\therefore a_1 r^3 \times a_1 r^5 = 9$$

$$a_1^2 r^8 = 9 \Rightarrow a_1 r^4 = 3$$

And

$$a_1(r^4 + r^6) = 24$$

$$\Rightarrow 3(1 + r^2) = 24$$

$$\therefore r^2 = 7 \text{ and } a_1 = \frac{3}{49}$$

Now

$$a_1 a_9 + a_2 a_4 a_8 + a_5 + a_7$$

$$= a_1^2 r^8 + a_1^3 r^{12} + 24$$

$$= 24 + \frac{9}{7^4} \times 7^4 + \frac{27}{7^6} \cdot 7^6 = 60$$

82. Five digit numbers are formed using the digits 1, 2, 3, 5, 7 with repetitions and are written in descending order with serial number. For example, the number 77777 has serial number 1. Then the serial number of 35337 is _____.

Answer (1436)

Sol. Given digits 1, 2, 3, 5, 7

and number 35337

$$7 \text{ _ _ _ _ } = 5^4 = 625$$

$$5 \text{ _ _ _ _ } = 5^4 = 625$$

$$37 \text{ _ _ _ } = 5^3 = 125$$

$$357 \text{ _ _ } = 5^2 = 25$$

$$355 \text{ _ _ } = 5^2 = 25$$

$$3537 \text{ _ } = 5$$

$$3535 \text{ _ } = 5$$

$$35337 = 1$$

$$\therefore \text{Serial no.} = 1436$$

83. Let the equation of the plane P containing the line

$$+10 = \frac{8-y}{2} = z \text{ be } ax + by + 3z = 2(a + b) \text{ and}$$

the distance of the plane P from the point $(1, 27, 7)$

be c . Then $a^2 + b^2 + c^2$ is equal to _____.

Answer (355)

Sol. Equation of the line:

$$+10 = \frac{8-y}{2} = z$$

and plane $P : ax + by + 3z = 2(a + b)$

\therefore line lies in P

$$\therefore -10a + 8b = 2a + 2b$$

$$12a = 6b \Rightarrow \boxed{b = 2a}$$

and

$$a - 2b + 3 = 0$$

$$\text{So, } \boxed{a=1} \quad \boxed{b=2}$$

Now distance of $(1, 27, 7)$ from $P = c$

$$\Rightarrow \frac{1+54+21-6}{\sqrt{14}} = c$$

$$\therefore a^2 + b^2 + c^2 = 1+4 + \frac{4900}{14} = 355$$

84. Let $f : \mathbb{R} \rightarrow \mathbb{R}$ be a differentiable function that satisfies the relation $f(x+y) = f(x) + f(y) - 1, \forall x, y \in \mathbb{R}$. If $f(0) = 2$, then $|f(-2)|$ is equal to _____.

Answer (03)

Sol. $f(x+y) = f(x) + f(y) - 1 \quad f(0) = 1$

$$f'(x) = \lim_{h \rightarrow 0} \frac{f(x+h) - f(x)}{h} = \lim_{h \rightarrow 0} \frac{f(x) + f(h) - 1 - f(x)}{h}$$

$$f'(x) = \lim_{h \rightarrow 0} \frac{f(h) - 1}{h}$$

$$f'(x) = f'(0)$$

$$f'(x) = 2$$

$$f(x) = 2x + c$$

$$\therefore f(0) = 1$$

$$1 = c$$

$$\Rightarrow c = 1$$

$$f(x) = 2x + 1$$

$$|f(-2)| = |2(+2)-1| = 3$$

85. Let the co-ordinates of one vertex of $\triangle ABC$ be $A(0, 2, \alpha)$ and the other two vertices lie on the line $\frac{x+\alpha}{5} = \frac{y-1}{2} = \frac{z+4}{3}$. For $\alpha \in \mathbb{Z}$, if the area of $\triangle ABC$ is 21 sq. units and the line segment BC has length $2\sqrt{21}$ units, then α^2 is equal to _____.

Answer (09)

Sol.

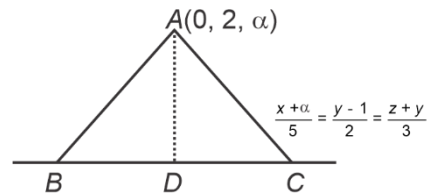

Let coordinate of $D = (5k - \alpha, 2k + 1, 3k - 4)$

$$\therefore D.R^s. \text{ of } AD = \langle 5k - \alpha, 2k - 1, 3k - 4 - \alpha \rangle$$

$$\therefore 5(5k - \alpha) + 2(2k - 1) + 3(3k - 4 - \alpha) = 0$$

$$\therefore 19k - 4\alpha - 7 = 0 \quad \dots(i)$$

$$\text{and } \frac{1}{2} \times 2\sqrt{21} \times AD = 21$$

$$\therefore AD = \sqrt{21}$$

$$\therefore (5k - \alpha)^2 + (2k - 1)^2 + (3k - 4 - \alpha)^2 = 21$$

$$\therefore 19k^2 - 8k\alpha + \alpha^2 - 14k + 4\alpha = 2 \quad \dots(ii)$$

from eq. (i) and (ii) : $\alpha = 3$

$$\therefore \alpha^2 = 9$$

86. Let \vec{a}, \vec{b} and \vec{c} be three non-zero non-coplanar vectors. Let the position vectors of four points A, B, C and D be $\vec{a} - \vec{b} + \vec{c}, \lambda\vec{a} - 3\vec{b} + 4\vec{c}, -\vec{a} + 2\vec{b} - 3\vec{c}$ and $2\vec{a} - 4\vec{b} + 6\vec{c}$ respectively. If $\overline{AB}, \overline{AC}$ and \overline{AD} are coplanar, then λ is equal to _____.

Answer (2)

Sol. $\overline{AB} = (\lambda - 1)\vec{a} + (-2)\vec{b} + 3\vec{c}$

$$\overline{AC} = -2\vec{a} + 3\vec{b} - 4\vec{c}$$

$$\overline{AD} = -\vec{a} - 3\vec{b} + 5\vec{c}$$

$\therefore \overline{AB}, \overline{AC}, \overline{AD}$ are co-planar

$$\begin{vmatrix} \lambda - 1 & -2 & 3 \\ -2 & 3 & -4 \\ 1 & -3 & 5 \end{vmatrix} [\vec{a} \vec{b} \vec{c}] = 0$$

$$\Rightarrow \begin{vmatrix} \lambda - 1 & -2 & 3 \\ -2 & 3 & -4 \\ 1 & -3 & 5 \end{vmatrix} = 0$$

$$3(\lambda - 1) - 2(6) + 3(6 - 3) = 0$$

$$3(\lambda - 1) - 12 + 9 = 0$$

$$3(\lambda - 1) = 3$$

$$\lambda = 2$$

87. Let the coefficients of three consecutive terms in the binomial expansion of $(1 + 2x)^n$ be the ratio 2 : 5 : 8. Then the coefficient of the term, which is in the middle of these three terms, is _____.

Answer (1120)

Sol. $\frac{{}^nC_r 2^r}{{}^nC_{r+1} 2^{r+1}} = \frac{2}{5}$

$$\frac{r+1}{n-r} = \frac{4}{5} \quad \dots(i)$$

$$\frac{{}^nC_{r+1} 2^{r+1}}{{}^nC_{r+2} 2^{r+2}} = \frac{5}{8}$$

$$\frac{r+2}{n-r-1} = \frac{5}{8} \quad \dots(ii)$$

Solving (i) and (ii)

$$r = 3, n = 8$$

$$\text{Middle term} = {}^nC_{r+1} (2)^{r+1}$$

$$= {}^8C_4 (2)^4$$

$$= 1120$$

88. Suppose f is a function satisfying $f(x+y) + f(x) + f(y)$ for all $x, y \in \mathbb{N}$ and $f(1) = \frac{1}{5}$. If

$$\sum_{n=1}^m \frac{f(n)}{n(n+1)(n+2)} = \frac{1}{12}, \text{ then } m \text{ is equal to}$$

_____.

Answer (10)

Sol. $f(x+y) = f(x) + f(y)$

$$\Rightarrow f(x) = kx$$

$$f(1) = \frac{1}{5} \Rightarrow k = \frac{1}{5}$$

$$\therefore f(x) = \frac{1}{5}x$$

$$\sum_{n=1}^m \frac{f(n)}{n(n+1)(n+2)} = \frac{1}{5} \sum_{n=1}^m \frac{n}{n(n+1)(n+2)} = \frac{1}{12}$$

$$\Rightarrow \frac{1}{5} \sum_{n=1}^m \frac{1}{(n+1)(n+2)} = \frac{1}{12}$$

$$\Rightarrow \frac{1}{5} \left[\frac{1}{2} - \frac{1}{m+2} \right] = \frac{1}{12}$$

$$\Rightarrow m = 10$$

89. If all the six digit numbers $x_1 x_2 x_3 x_4 x_5 x_6$ with $0 < x_1 < x_2 < x_3 < x_4 < x_5 < x_6$ are arranged in the increasing order, then the sum of the digits in the 72th number is _____.

Answer (32)

Sol. 1 $\rightarrow {}^8C_5 = 56$

$$23 \dots \rightarrow {}^6C_4 = \frac{15}{71}$$

$$72^{\text{th}} \text{ number} = 245678$$

$$\text{Sum} = 32$$

90. If the co-efficient of x^9 in $\left(\alpha x^3 + \frac{1}{\beta x}\right)^{11}$ and the co-efficient of x^{-9} in $\left(\alpha x - \frac{1}{\beta x^3}\right)^{11}$ are equal, then $(\alpha\beta)^2$ is equal to _____.

Answer (01)

Sol. $T_{r_1+1} = {}^{11}C_{r_1} (\alpha x^3)^{11-r_1} (\beta x)^{-r_1}$

$$= {}^{11}C_{r_1} \alpha^{11-r_1} \beta^{-r_1} x^{33-4r_1}$$

$$33 - 4r_1 = 9 \Rightarrow r_1 = 6$$

$$T_{r_2+1} = {}^{11}C_{r_2} (\alpha x)^{11-r_2} (-1)^{r_2} (\beta x^3)^{-r_2}$$

$$= (-1)^{r_2} {}^{11}C_{r_2} \alpha^{11-r_2} \beta^{-r_2} x^{11-4r_2}$$

$$11 - 4r_2 = -9 \Rightarrow r_2 = 5$$

Equating the coefficients

$${}^{11}C_6 \alpha^5 \beta^{-6} = {}^{11}C_5 \alpha^6 \beta^{-5}$$

$$\Rightarrow \alpha\beta = 1$$

